

# ESJ100SH120K

## Trench/Fieldstop IGBT module

### ■ Features

- Low  $V_{CE(sat)}$
- $BV_{CES} = 1250V$
- Fast & Soft Anti-Parallel FWD
- Short circuit rated : Min. 10uS at  $T_C=100^{\circ}C$
- Reduced EMI and RFI
- Isolation Type Package

### ■ Applications

- Welding Machine
- Induction Heating
- UPS Systems
- Motor Drives

### Equivalent Circuit and Package

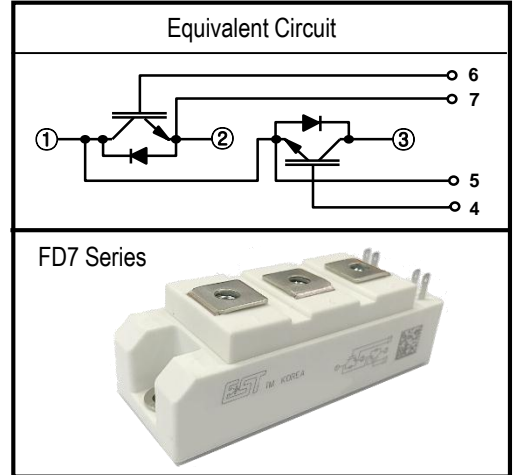

Please see the package out line information

### ■ Absolute Maximum Ratings @ $T_C=25^{\circ}C$ (Per Leg)

Symbol	Parameter	Conditions	Ratings	Unit
$V_{CES}$	Collector-emitter voltage	-	1250	V
$V_{GES}$	Gate-emitter peak voltage	-	$\pm 20$	V
$I_C$	DC-collector current	$T_C = 25^{\circ}C$	200	A
		$T_C = 80^{\circ}C$	100	A
$I_{CM}^{(1)}$	Repetitive peak collector current	1ms	200	A
$I_F$	Diode continuous forward current	$T_C = 80^{\circ}C$	100	A
$I_{FM}$	Diode repetitive peak forward current	-	200	A
$T_J^{(2)}$	Operating junction temperature	-	-40 ~ 125	$^{\circ}C$
$T_{stg}$	Storage temperature range	-	-40 ~ 125	$^{\circ}C$
$V_{ISO}$	Insulation test voltage	60Hz, t=1min $I_{ISOL}=1mA$	2.5	kV
$M_S$	Mounting screw torque	M6	3.0 ~ 6.0	N.m
$M_t$	Mounting terminals screw torque	M5	2.5 ~ 5.0	N.m

(Note \*1) Repetitive rating : Pulse width limited by max junction temperature

(Note \*2) The maximum junction temperature of chip is 150 $^{\circ}C$

**Electrical Characteristics of IGBT @  $T_c=25^\circ\text{C}$  (unless otherwise specified)**

Symbol	Parameter	Conditions	Min.	Typ.	Max.	Unit	
$BV_{CES}$	C - E Breakdown Voltage	$V_{GE} = 0V, I_C = 100\mu A$	1250	-	-	V	
$V_{GE(th)}$	G-E threshold voltage	$I_C = 1mA, V_{CE} = V_{GE}$	4.8	-	6.8	V	
$I_{CES}$	Zero gate voltage collector current	$V_{GE} = 0V, V_{CE} = 1250V$	-	-	100	$\mu A$	
$I_{GES}$	G-E leakage current	$V_{GE} = \pm 20V, V_{CE} = 0V$	-	-	$\pm 0.5$	$\mu A$	
$R_{Gint}$	Internal Gate Resistor	-	-	5.0	-	$\Omega$	
$V_{CE(Sat)}$	C-E saturation voltage	$I_C = 100A, V_{GE} = 15V, T_J = 25^\circ\text{C}$	-	2.2	2.6	V	
		$I_C = 100A, V_{GE} = 15V, T_J = 125^\circ\text{C}$	-	2.7	-	V	
$C_{ies}$	Input capacitance	$V_{GE} = 0V, f = 1MHz, V_{CE} = 25V$	-	8725	-	pF	
$C_{oes}$	Output capacitance		-	3415	-		
$C_{res}$	Reverse transfer capacitance		-	1085	-		
$td(on)$	Turn-on delay time	$V_{CE} = 600V, I_C = 100A,$ $V_{GE} = \pm 15V, R_G = 10\Omega,$ $T_J = 25^\circ\text{C},$ Inductive load	-	155	-	ns	
$t_r$	Turn-on rise time		-	145	-		
$td(off)$	Turn-off delay time		-	490	-		
$t_f$	Turn-off fall time		-	45	-		
$E_{on}$	Turn-on Energy loss		-	13.0	-		mJ
$E_{off}$	Turn-off Energy loss		-	5.6	-		
$td(on)$	Turn-on delay time	$V_{CE} = 600V, I_C = 100A,$ $V_{GE} = \pm 15V, R_G = 10\Omega,$ $T_J = 125^\circ\text{C},$ Inductive load	-	220	-	ns	
$t_r$	Turn-on rise time		-	155	-		
$td(off)$	Turn-off delay time		-	520	-		
$t_f$	Turn-off fall time		-	40	-		
$E_{on}$	Turn-on Energy loss		-	17.2	-		mJ
$E_{off}$	Turn-off Energy loss		-	6.7	-		
$T_{sc}$	Short Circuit Withstand Time	$V_{CC} = 600V, V_{GE} = 15V, @T_c = 100^\circ\text{C}$	10	-	-	$\mu s$	
$Q_g$	Total gate charge	$V_{GE} = \pm 15V, V_{CE} = 600V, I_C = 100A$	-	690	-	nC	

**Electrical Characteristics of FRD @  $T_C=25^\circ\text{C}$  (unless otherwise specified)**

Symbol	Parameter	Conditions	Min.	Typ.	Max.	Unit	
$V_{FM}$	Diode Forward Voltage	$I_F=100\text{A}$	$T_J=25^\circ\text{C}$	-	2.6	3.0	V
			$T_J=125^\circ\text{C}$	-	2.6	-	
$t_{rr}$	Diode Reverse Recovery Time		$T_J=25^\circ\text{C}$	-	125	165	ns
			$T_J=125^\circ\text{C}$	-	155	-	
$I_{rr}$	Diode Peak Reverse Recovery Current	$I_F=100\text{A}, V_R=600\text{V}$ $di/dt=-1100\text{A}/\mu\text{S}$	$T_J=25^\circ\text{C}$	-	95	-	A
			$T_J=125^\circ\text{C}$	-	110	-	
$Q_{rr}$	G-E leakage current		$T_J=25^\circ\text{C}$	-	5937	-	nC
			$T_J=125^\circ\text{C}$	-	8525	-	

**Thermal Characteristics and Weight**

Symbol	Parameter	Conditions	Min.	Typ.	Max.	Unit
$R_{\theta JC}$	Junction-to-Case	per IGBT	-	-	0.22	$^\circ\text{C}/\text{W}$
$R_{\theta JC}$	Junction-to-Case	per DIODE	-	-	0.45	$^\circ\text{C}/\text{W}$
$R_{\theta CK}$	Case-to-Heatsink (Conductive grease applied)	per IGBT	0.05	-	-	$^\circ\text{C}/\text{W}$
Weight	Weight of Module		-	-	160	g

## Performance Curves

Fig. 1 Typical IGBT output characteristics ( $T_J = 25^\circ\text{C}$ )

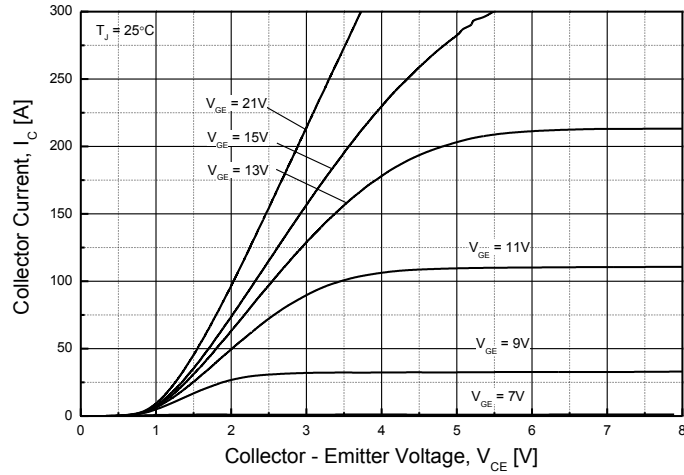

Fig. 2 Typical IGBT output characteristics ( $T_J = 125^\circ\text{C}$ )

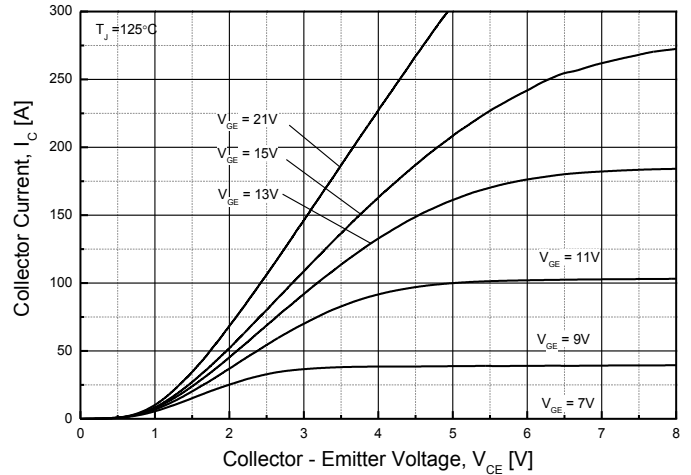

Fig. 3 Typical IGBT output characteristics

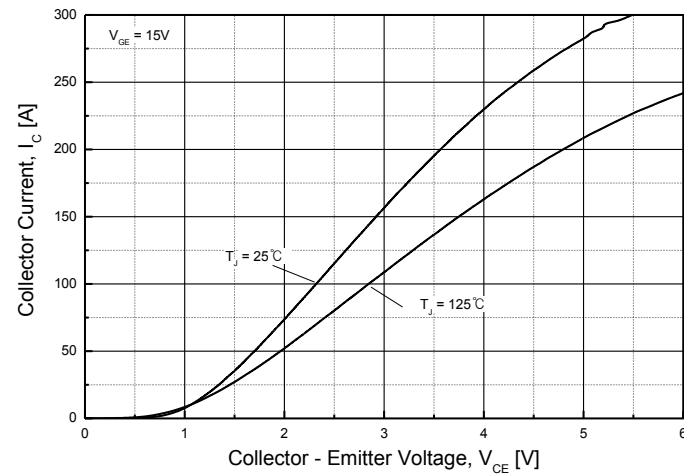

Fig. 4 Typical diode forward characteristics

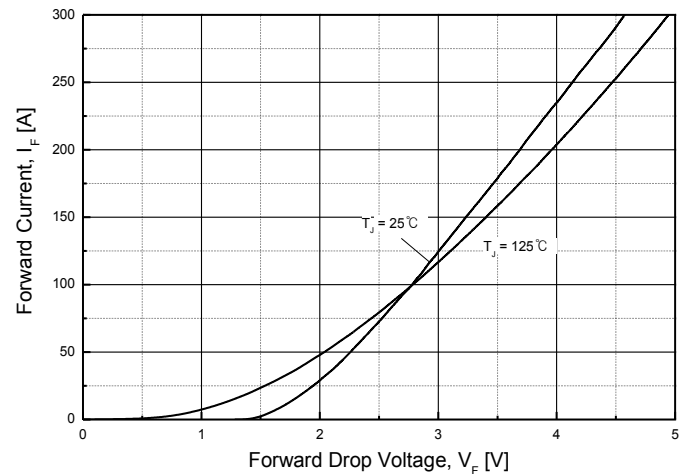

Fig. 5 Typical Switching Energy Loss =  $f(R_G)$   
 $V_{GE} = \pm 15\text{V}$ ,  $I_C = 100\text{A}$ ,  $V_{CE} = 600\text{V}$ ,  $T_J = 25^\circ\text{C}$

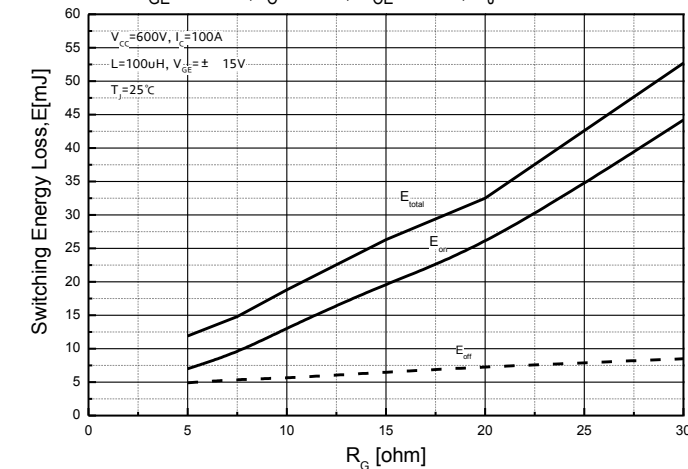
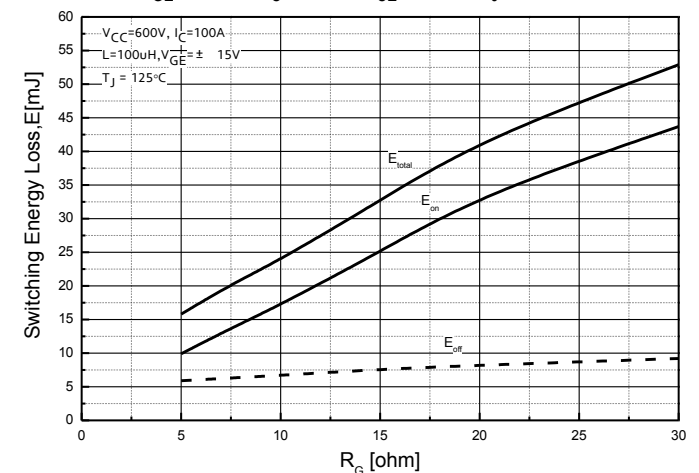

Fig. 6 Typical Switching Energy Loss =  $f(R_G)$   
 $V_{GE} = \pm 15\text{V}$ ,  $I_C = 100\text{A}$ ,  $V_{CE} = 600\text{V}$ ,  $T_J = 125^\circ\text{C}$



## Performance Curves

Fig. 7 Typical Switching Energy Loss =f(I<sub>c</sub>)  
 $V_{GE} = \pm 15V, R_G = 10\Omega, V_{CE} = 600V, T_j = 25^\circ C$

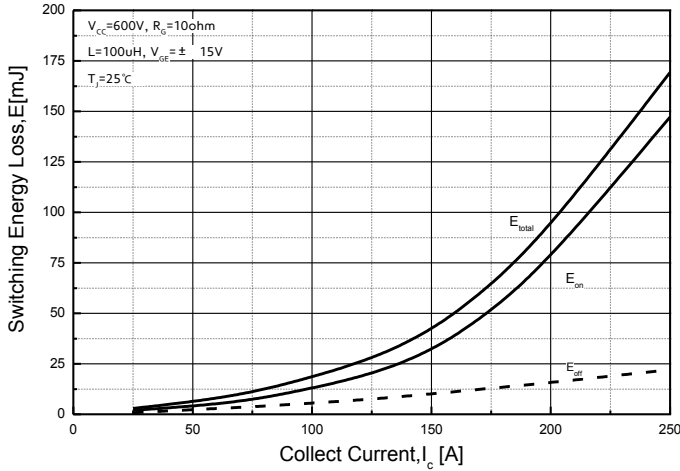

Fig. 8 Typical Switching Energy Loss =f(I<sub>c</sub>)  
 $V_{GE} = \pm 15V, R_G = 10\Omega, V_{CE} = 600V, T_j = 125^\circ C$

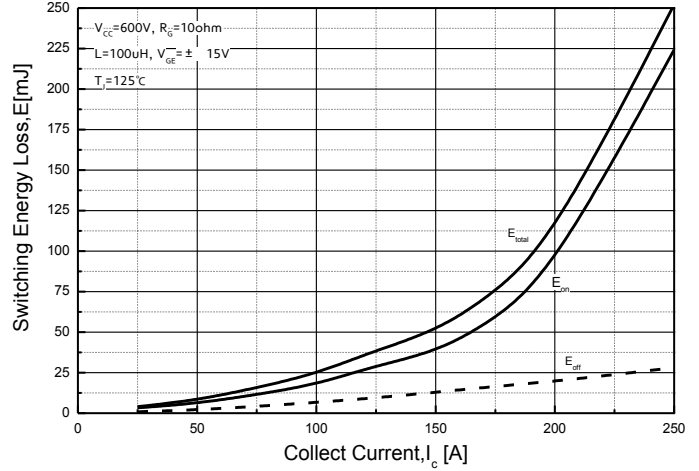

Fig. 9 Gate Charge Characteristics

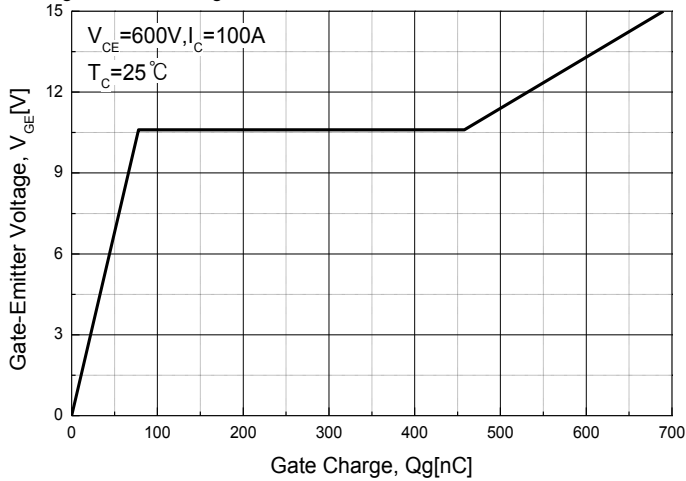
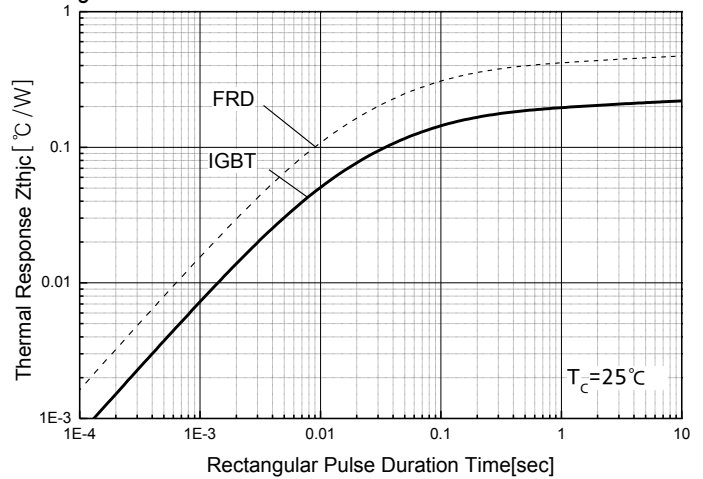

Fig. 10 Transient Thermal Resistor



## Package Out Line Information

### FD7 Package

Dimensions in mm

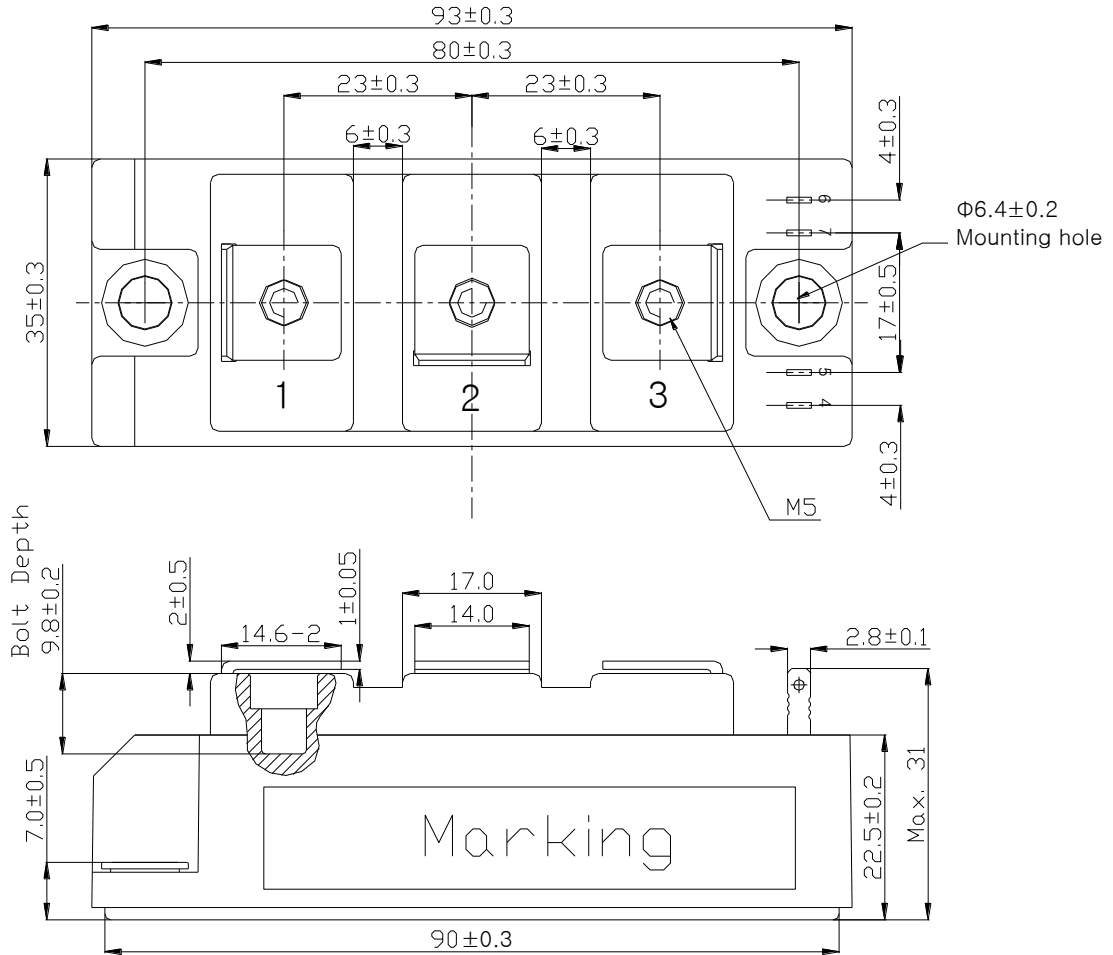

## Internal Circuit

